

**GAM PATTERN TIPS**

GAM Products is here to help you achieve the best results with our products. GAM strives to see that every pattern you receive meets exacting quality standards. GAM inspects each and every pattern before it is sold. GAM also has an ongoing research program to insure that the best possible materials; the steel, the chemicals used for the etching process, and the best possible etching equipment are used in the manufacture of GAM Patterns.

The etching quality of the pattern is of key importance. GAM patterns start with the best possible highly heat resistant steel, the composition of the steel is more important than the thickness, although, some heat resistant steels are not suitable for pattern production because the molecular structure prohibits the clean etching required. The holes in the design should have clean, smooth, straight-walled edges. Lines should be solid, not chewed up.

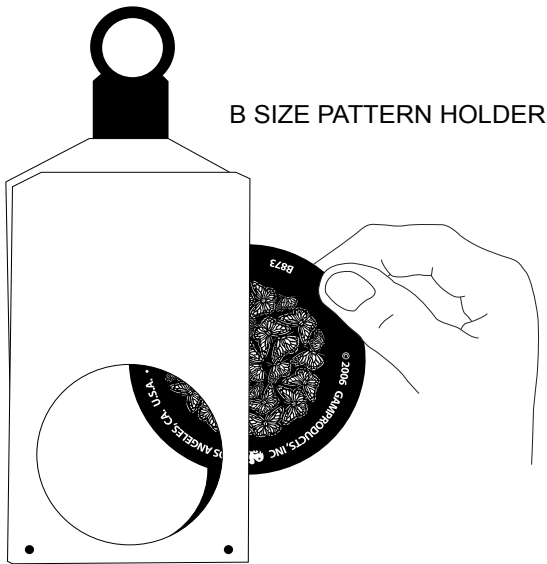

B SIZE PATTERN HOLDER

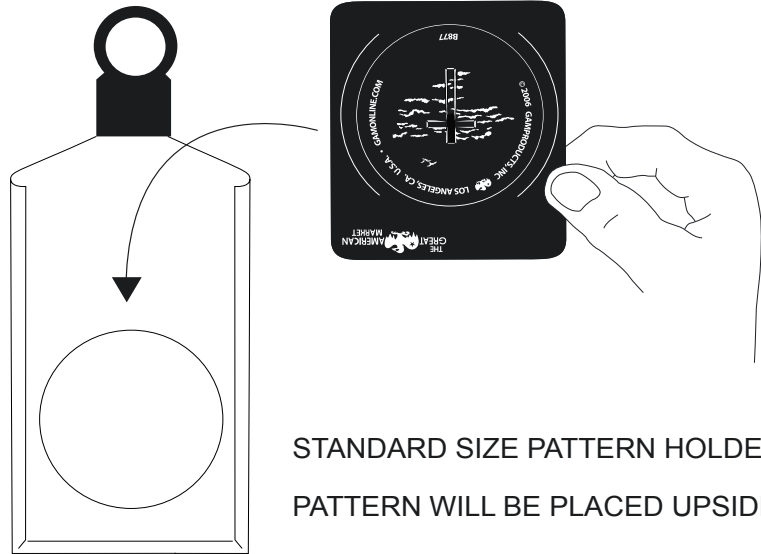

STANDARD SIZE PATTERN HOLDER  
 PATTERN WILL BE PLACED UPSIDE DOWN

The design area should be free of nicks and scratches. The pattern is only one aspect of getting the best image. The type of pattern holder is also important. Heat plays a critical role in the performance of a pattern. You want to dissipate the heat from the pattern. The best type of pattern holder is the 'sandwich style' holder, which grips the pattern firmly all around the design and aids in heat dissipation. The faster heat is drawn away from the pattern the longer it will last. The 'sandwich style' pattern holder also precludes accidental dropping of the pattern into the gate of the fixture during insertion and removal. It also aids in maintaining a uniform focus.

A pattern can be trimmed to fit the odd size pattern holder. It is important to leave as much 'meat' as you can so that the heat will be distributed over as large an area as possible. GAM's standard pattern, is designed to fit odd size pattern holders.

The life of a pattern and the quality of the image are dependent on the pattern itself and on the fixture used to project the image. Stainless steel patterns can warp and burn from the concentration of heat on the surface. This concentration at the gate is inherent in the optical design of the ellipsoidal spotlight. Some fixtures are designed "hotter" than others and therefore are harder on the patterns used in them. It is important to have your ellipsoidal spotlight cleaned and aligned for projecting images. A little maintenance will greatly improve the quality of the images and extend the life of the pattern.



You will need to take the ellipsoidal spotlights apart to clean the lenses and then you will need to optically align the lamp. Every make and model of ellipsoidal is different. If you are not sure how to do this, check with the manufacturer of the ellipsoidal or the local stage lighting dealer. One of those two sources should be able to provide the needed information. In order to get the best possible image and extend the life of your patterns, three tasks need to be performed. First the lenses need to be cleaned, then the reflector needs to be cleaned, and finally, the lamp (bulb) needs to be optically aligned. These three steps will greatly enhance the quality of the image and extend the life of your patterns. All of us have looked into the lens of a light and asked ourselves "is there a frost gel in that light"? In most cases, it is likely that the lens is just dirty. The first step is to remove the lens barrel from the fixture. Be careful to keep track of the knob when you remove it. Try putting it back in the lens barrel if possible. If that is not possible, make sure you put the knob in a safe place. Replacement knobs can be hard to find. Once you have the lens barrel out, take out the lenses. Make sure to keep track of where each lens goes and how each is oriented. You will greatly affect the output from the ellipsoidal if you put a lens in the wrong place or the wrong orientation. Now, clean the lenses. Some lenses have a coating on them, so only use clean distilled water and a soft lint free cloth. Before you put the lenses back in the lens barrel, make sure that the lenses are truly clean, free of fingerprints, and are in the correct place and orientation.

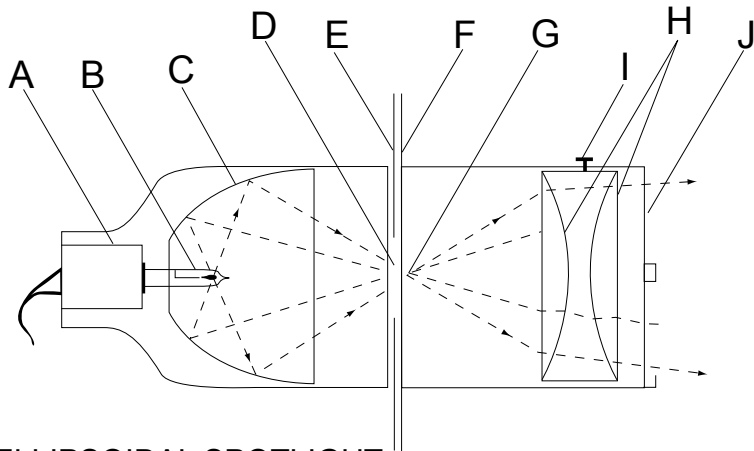

- A SOCKET
- B LAMP
- C REFLECTOR
- D GATE
- E FRAMING SHUTTERS
- F PATTERN HOLDER - PLACE PATTERN
- G FOCAL POINT - RAYS OF REFLECTED LIGHT CONVERGE HERE
- H PLANO CONVEX LENSES
- I LENS FOCUSING KNOB
- J COLOR FRAME HOLDER

ELLIPSOIDAL SPOTLIGHT

Now the reflector needs to be cleaned. With the lens barrel and lenses removed, open up the fixture to get easy access to the reflector. It is important to remove the lamp (bulb) from the fixture. This makes it easier and safer to clean the reflector. When cleaning the reflector, try using compressed air to remove the surface dust. It is the safest method. Using compressed air lessens the chance of damaging the reflector. However, if the reflector is very dirty, the surface dirt on of the reflector needs to be removed. There are two ways to achieve this. The first method is to use a soft bristled paint brush. Make sure to use a new, clean, soft bristled paint brush to clean reflectors. It is imperative not to scratch or leave a residue on the reflector. If the brush does not work, use a clean, lint free, damp cloth. Dampen the cloth with distilled water only. Do not use anything that might damage the surface of the reflector or leave a residue on it.

Once the lenses and the reflector are clean, the light can be reassembled. The last and most important step is to optically align the lamp. Lamp alignment is the single most important factor in extending pattern life. When an ellipsoidal spotlight is used to light actors, the lamp is often adjusted to produce a hot center and a feathered edge. When using the same fixture to project an image, it is preferable to back the lamp out of the reflector until the field of light is even all the way across, with no 'hot spot'. With an even field, the heat is distributed over the whole surface of the pattern, rather than concentrated on one part. In addition, the even field allows for a more uniform focus.

Most ellipsoidals have screws and/or knobs and socket mounting plates to align the lamps. First, center the lamp filament in the field of light. Then, adjust penetration into the reflector. Consult the fixture's manufacturer instructions for more details. It is easiest to align an ellipsoidal when it is down and on a dimmer at a lower intensity. The fixture should be focused on a flat white surface. Aligning a lamp can be a difficult process, but is worth the time; it will extend the life of the pattern and improve the quality of the image. If the ellipsoidal has been properly cleaned and aligned, it is ready to project your image. A little bit of work on the ground will reap great rewards when the image is focused on the stage.