

SX4® LOOP TRAY SPECIFICATIONS **Catalog # TS6210**



Fire / Waves Effect Loop

Professional Scenic Projection System

- For theme parks, display & theatrical applications
- Slides into SX4® Case mounted in ETC Source Four™
- Over 40 pattern loops available off-the-shelf
- Custom pattern loops available
- Integrated speed control and reverse switch - *Integrated control can be used with dimmer for mastering a group of SX4®'s and for control from a light board*
- Pattern loop life span is 4,000 hours of continuous use - *ideal for theme park and retail applications*

The SX4® Loop Tray is designed to fit into the SX4® Case which is attached to an ETC Source Four™ fixed focus Ellipsoidal spotlight (see SX4® Case Specifications). The Loop Tray will accept a continuous loop pattern. The speed and direction of the loop are varied with onboard controls and the speed can also be controlled from a dimmer.

With a large number of off-the-shelf effects using GAM FX/Loops you can quickly create a variety of different projected images. Moving clouds, rain, snow, fire, water ripples, water falls, stars and so much more are as easy as selecting the appropriate FX/Loop from your catalog. The SX4® has been used on Broadway, in operas, film and television productions, special events, retail store displays, anywhere that a special lighting effect is required. Reliable, efficient, long life and easy to use features set the SX4® projection system apart from all other choices.

Item #	Description
TS6100	SX4® Loop Tray 120 Volt (With SX4® case)
TS6102	SX4® Loop Tray 230 Volt (With SX4® case)
TS6210	SX4® Loop Tray (no case)

Add FS to catalog number for shutters.

Ex: SX4® with 230 Volt Loop Tray **TS6102FS**



SX4® Loop Tray
 US Patent # 6,926,427
 August 9, 2005

Dimensions:

- Wide: 11 ⁵/₁₆ in. (28.7 cm)
- Height: 11 ¹/₄ in. (28.5 cm)
- Deep: 3 ¹/₈ in. (7.9 cm)
- Weight : 3 lbs., 5 oz. (1.44 kgs.)
- With SX4 Case: 9lbs., 10 oz. (4.28 kgs.)
- Finish: Matte black paint

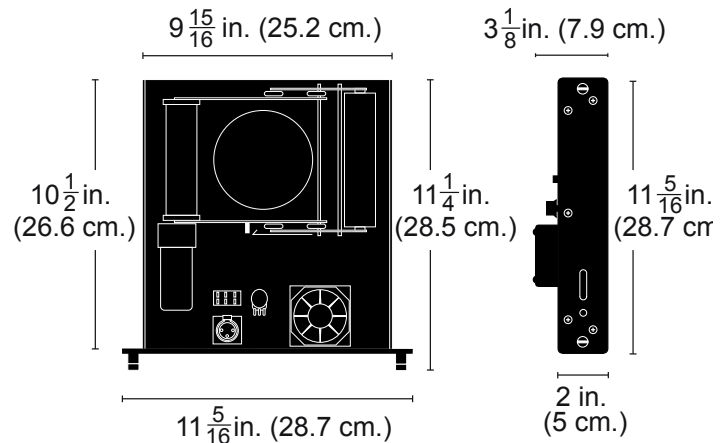

FRONT VIEW

BOTTOM VIEW

The frame for the SX4[®] Film Loop Tray shall be manufactured from .063 inch (1.6 cm.) thick aluminum to minimize weight. The overall dimensions shall be 11-5/16 inches (28.7 cm.) wide at the bottom, 11-1/4 inches (28.5 cm.) high, and 3-1/8 inches (7.9 cm.) deep including fan protective housing. The spring tensioned loop roller shall be made of aluminum and the drive roller attached to the motor shall also be made of aluminum. Roller assembly plate and support systems shall be made of .065 inch (1.65 cm.) steel for rigidity. Roller will have an automatic locking device which allows it to be compressed for FX/Loop placement, and it can be easily released to operating position to maintain balanced spring tension on the loop. Low voltage 12 Volt Pittman Motor shall drive the fixed roller with silent gear box. Loop Tray shall contain internal electronic speed control, reversing switch and panel mounted recessed 3-pin locking XLR connector. Speed shall be varied through a control knob mounted on tray next to the long life, low voltage, cooling fan.

When Film/Loop Tray slides into the SX4[®] Case it will automatically lock and be held in place. 2 captive securing bolts will be threaded into place without requiring the unit to be handheld in its position.

Provide power transformer with attached 2-pin Edison male connector input and 3-pin female output, locking XLR connector on a 6-foot (182.8 cm.) heat shielded wire. Power supply shall be 120 Volts AC input at 60 Hz (12 W) and provide 12 Volt DC output 500mA to the motor and fan. Power supply shall operate either from standard line voltage or when plugged into a dimmer and speed controlled by the dimmer. SX4[®] Loop Tray shall weigh 3 lbs.5 oz. (1.5 kgs.) and with the SX4[®] Case, it shall weigh 9lbs.10oz (4.36 kgs.). It is finished with powder coated matte black and shall be model number **TS6210** as manufactured by GAMPRODUCTS, INC., Los Angeles, California.

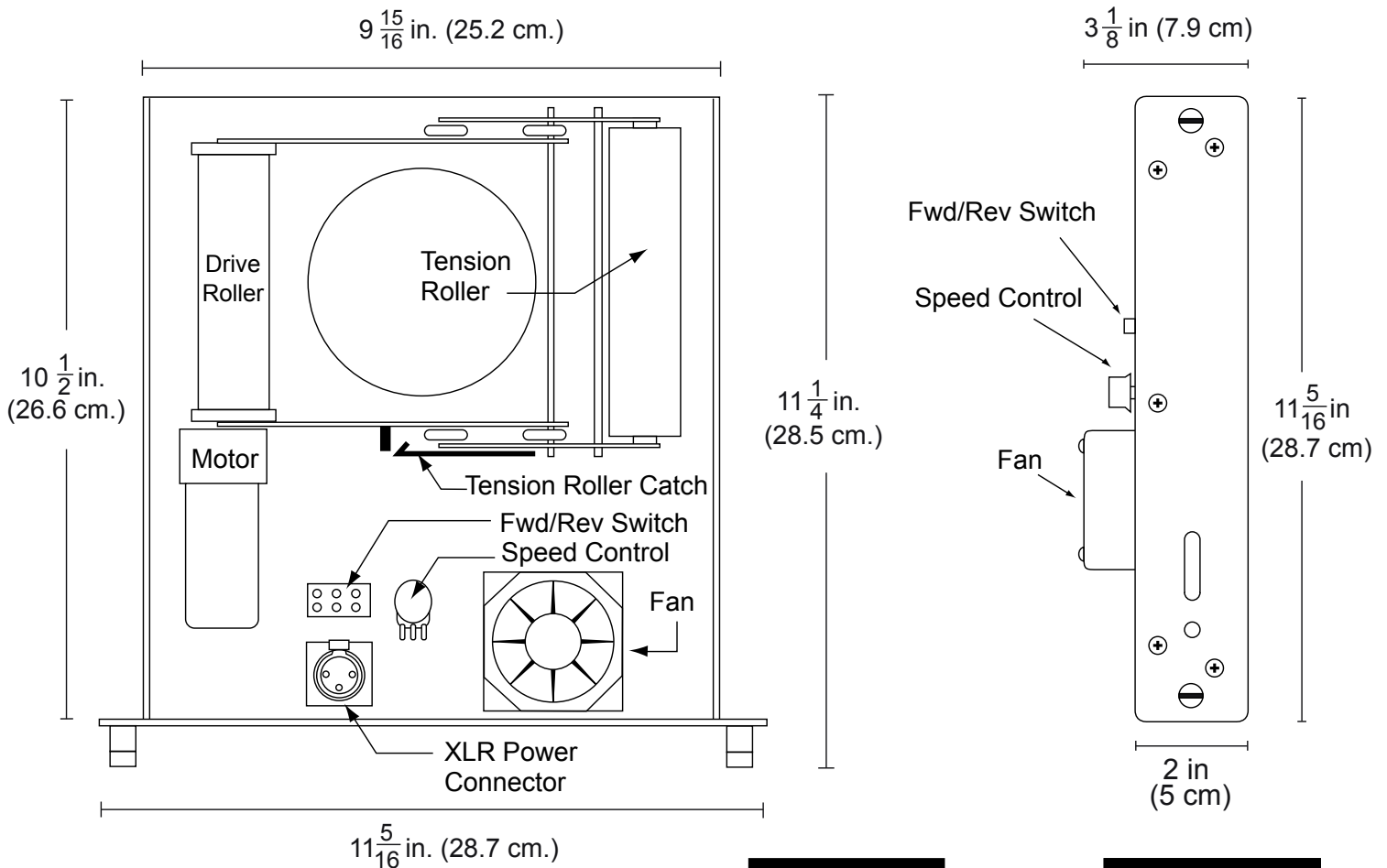

FRONT VIEW

BOTTOM VIEW

Item #	Description
TS6100	SX4 [®] Loop Tray 120 Volt
TS6102	SX4 [®] Loop Tray 230 Volt
TS6210	SX4 [®] Loop Tray

Add FS to catalog number for shutters.
 Ex: SX4[®] with 230 Volt Loop Tray **TS6102FS**